



2009 Amendment # 1
August 2009

Amendment of:
Standard Details #205 and #206

City of West Sacramento
Standard Specifications 2002

Effective September 12, 2009

The following amendment represents a minor revision to the "Community Development Department Engineering Division Standard Specifications 2002". This amendment supersedes the prior document. Therefore, it is recommended that all Standard Specifications holders insert this packet into the front of the "Community Development Department Engineering Division Standard Specifications 2002" and refer to them as necessary.

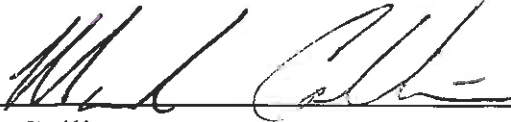

Mark Collier, P.E. No. 54031 9/12/09
Supervising Civil Engineer Date

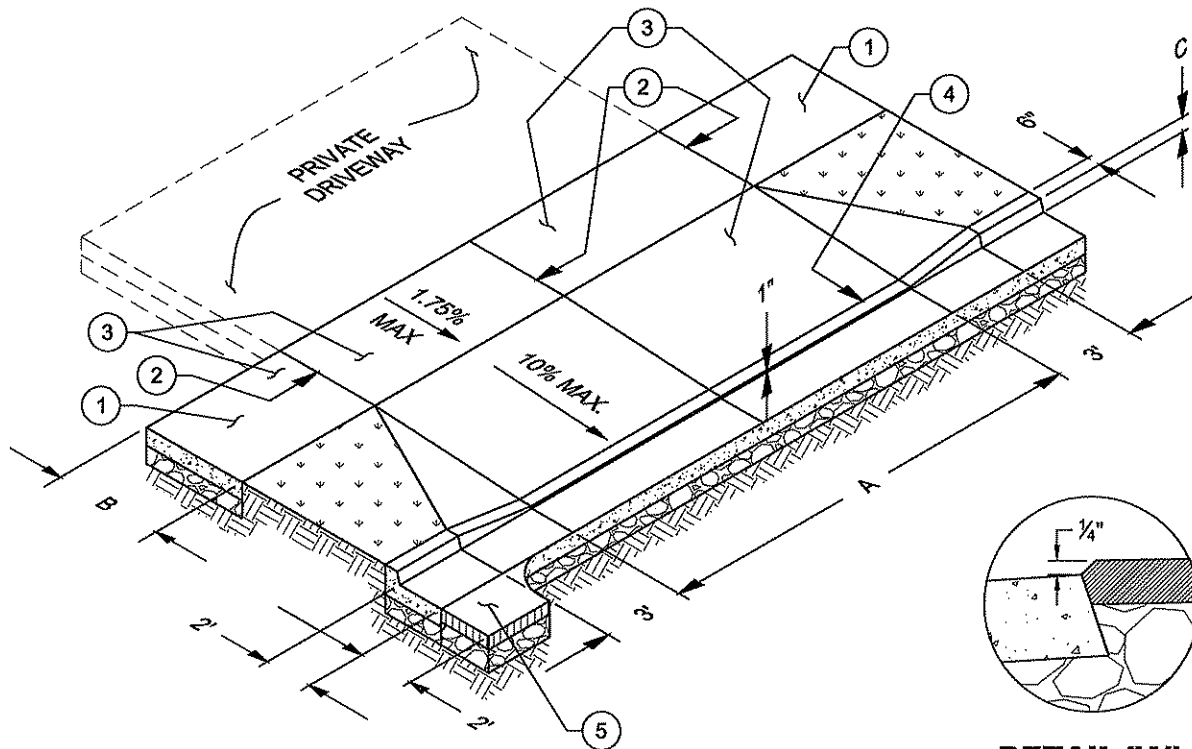

DETAIL "A"

- ① STANDARD CITY SIDEWALK.
- ② DEEP TOOL JOINT. (MAX. SPACING 12 FEET)
- ③ CLASS "A" CONCRETE, 6 INCHES THICK FOR RESIDENTIAL, 8 INCHES THICK FOR COMMERCIAL/INDUSTRIAL WITH #4 REBAR, 12 INCHES O.C., PLACED ON 4" COMPACTED CLASS II AB OVER 6 INCHES OF SUBGRADE OR CLASS II AB. ALL AB AND/OR SUBGRADE SHALL BE PROCESSED TO 95% RELATIVE COMPACTION.
- ④ SCORE MARK, TYPICAL.
- ⑤ SAW CUT AND REMOVE EXISTING STREET SECTION. PLACE 6" THICK ASPHALT CONCRETE PATCH OR MATCH EXISTING, WHICHEVER IS GREATER. STREET SECTION SHALL BE 1/4" ABOVE LIP OF GUTTER. SEE DETAIL "A".

NOTES AND DIMENSIONS:

- A. PER DESIGN STANDARDS.
- B. MATCH EXISTING, OR SEE DIVISION I, SECTION 3, TABLE 3.01 OF THESE STANDARDS.
- C. CURB HEIGHT VARIES FOR EXISTING; STANDARD IS 6 INCHES.
- D. WHEN DRIVEWAY IS CONSTRUCTED WITHIN EXISTING SIDEWALK AREAS, THE NEW DRIVEWAY SECTION, INCLUDING THE CURB AND GUTTER, SHALL BE DOWELED INTO THE EXISTING CONCRETE WITH 12 INCH LENGTHS OF #4 REBARS AT 18 INCH CENTERS. THE #4 REBARS SHALL BE RETROFITTED BY CORING AND DRILLING EXISTING CONCRETE (4" MIN.), INSTALLING REBARS, AND FILLING ANNULAR VOIDS WITH EPOXY.
- E. LIGHT BROOM FINISH PERPENDICULAR TO STREET CENTERLINE ON CURB, GUTTER & SIDEWALK.

THE CITY OF WEST SACRAMENTO - STANDARD DETAIL

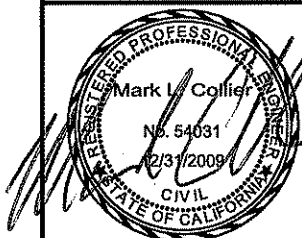

STANDARD
DETAIL #

205

TITLE:

**DRIVEWAY WITH CURB AND
GUTTER SEPARATE FROM
SIDEWALK**



DATE APPROVED: 8/12/2009

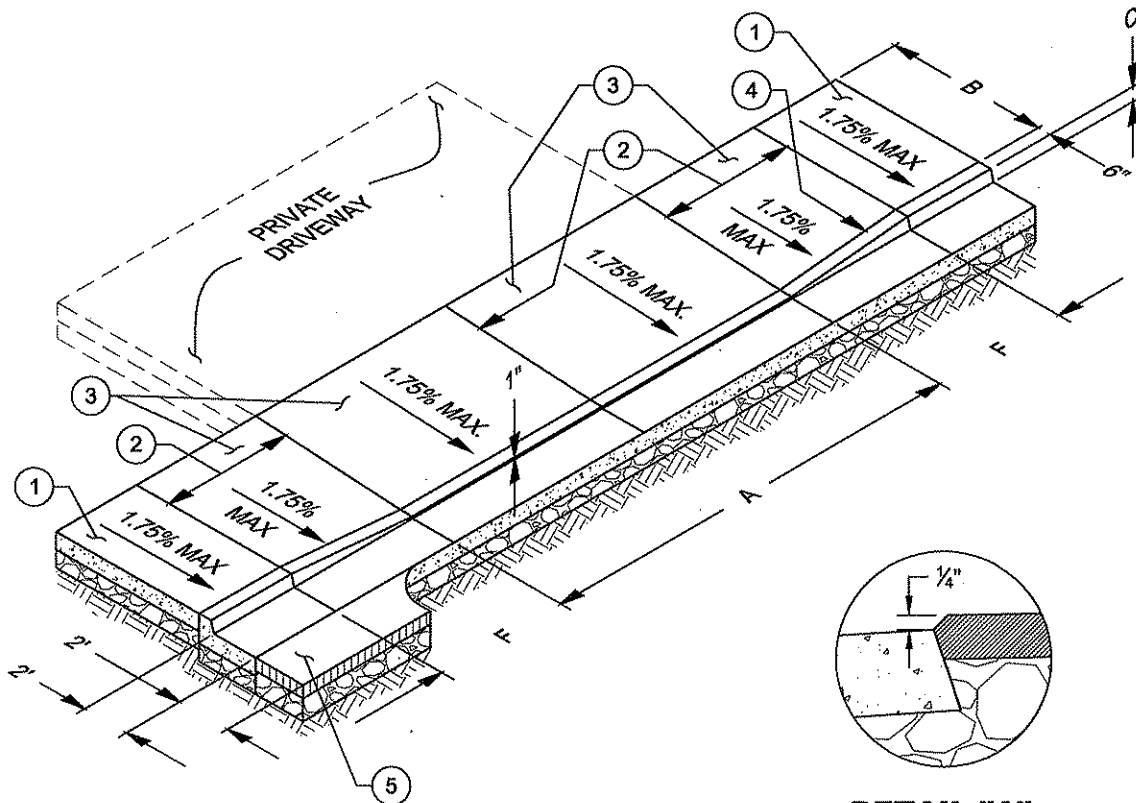

DETAIL "A"

- ① STANDARD CITY SIDEWALK.
- ② DEEP TOOL JOINT. (MAX. SPACING 12 FEET)
- ③ CLASS "A" CONCRETE, 6 INCHES THICK FOR RESIDENTIAL, 8 INCHES THICK FOR COMMERCIAL/INDUSTRIAL WITH #4 REBAR, 12 INCHES O.C., PLACED ON 4" COMPACTED CLASS II AB OVER 6 INCHES OF SUBGRADE OR CLASS II AB. ALL AB AND/OR SUBGRADE SHALL BE PROCESSED TO 95% RELATIVE COMPACTION.
- ④ SCORE MARK, TYPICAL.
- ⑤ RETROFIT: SAW CUT AND REMOVE EXISTING STREET SECTION. PLACE 6" THICK ASPHALT CONCRETE PATCH OR MATCH EXISTING, WHICHEVER IS GREATER. STREET SECTION SHALL BE 1/4" ABOVE LIP OF GUTTER. SEE DETAIL "A".

NOTES AND DIMENSIONS:

- A. PER DESIGN STANDARDS.
- B. MATCH EXISTING, OR SEE DIVISION I, SECTION 3, TABLE 3.01 OF THESE STANDARDS.
- C. CURB HEIGHT VARIES FOR EXISTING; STANDARD IS 6 INCHES.
- D. WHEN DRIVEWAY IS CONSTRUCTED WITHIN EXISTING SIDEWALK AREAS, THE NEW DRIVEWAY SECTION, INCLUDING THE CURB AND GUTTER, SHALL BE DOWELED INTO THE EXISTING CONCRETE WITH 12 INCH LENGTHS OF #4 REBARS AT 18 INCH CENTERS. THE #4 REBARS SHALL BE RETROFITTED BY CORING AND DRILLING EXISTING CONCRETE (4" MIN.), INSTALLING REBARS, AND FILLING ANNULAR VOIDS WITH EPOXY.
- E. LIGHT BROOM FINISH PERPENDICULAR TO STREET CENTERLINE ON CURB, GUTTER & SIDEWALK.
- F. LENGTH VARIES WITH CURB HEIGHT. MAXIMUM RUNNING SLOPE SHALL BE 7.5%

THE CITY OF WEST SACRAMENTO - STANDARD DETAIL

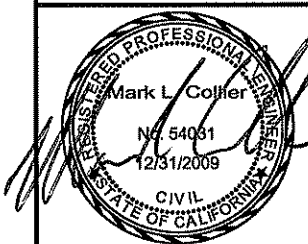

STANDARD
DETAIL #
206

TITLE:
**DRIVEWAY WITH CURB AND
GUTTER MONOLITHIC TO
SIDEWALK**



DATE APPROVED: 8/12/2009