

CONCRETE MEDIAN ISLAND

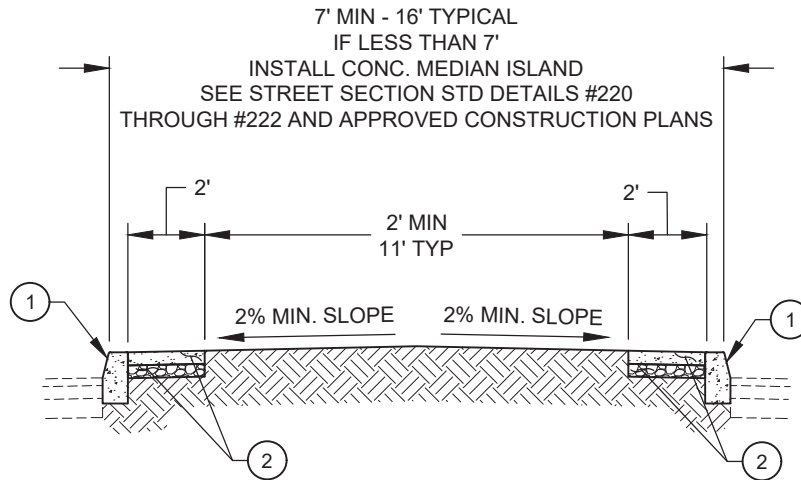

LANDSCAPED MEDIAN ISLAND

①	TYPE "A" MEDIAN CURB PER DETAIL #203
②	4" CONCRETE OR TEXTURED CONCRETE OVER 4" CLASS II AB PROCESSED TO 95% RELATIVE COMPACTION. CONCRETE SHALL BE 4,000 PSI MIN.

NOTES:

- A. PLACE 1½" DEEP TOOL JOINTS AT TWELVE (12) FOOT INTERVALS.
- B. WHERE PEDESTRIAN REFUGE AREA IS REQUIRED SEE STANDARD DETAIL #214.

THE CITY OF WEST SACRAMENTO - STANDARD DETAIL



APPROVED: Aug. X, 2025

STANDARD
DETAIL #
204

TITLE:
MEDIAN ISLAND

