

**NOTES:**

- A. SLOPES MAY BE CHECKED WITH A 2-FOOT SMART LEVEL.
- B. RAMPS SHALL HAVE A HEAVY BROOM FINISH TRANSVERSE TO THEIR SLOPE.
- C. LIMITS OF RAMP AREA IS ALL AREA SHOWN ON DETAIL. NO PULL BOX, UTILITY VAULT, UTILITY POLE, MANHOLE OR SIMILAR APPURTENANCE SHALL BE LOCATED WITHIN THE RAMP AREA WITHOUT PRIOR WRITTEN APPROVAL BY THE CITY ENGINEER.
- D. LANDING AT TOP OF RAMP SHALL NOT EXCEED 1.75% MAX SLOPE IN ANY DIRECTION.
- E. TRANSITIONS TO SIDEWALK, GUTTER AND STREETS SHALL BE FLUSH AND FREE OF ABRUPT CHANGE.
- F. RAMP SHALL BE DESIGNED AND CONSTRUCTED SUCH THAT WATER DOES NOT ACCUMULATE ON RAMP.
- G. DETECTABLE WARNING SURFACE SHALL EXTEND THE FULL WIDTH OF THE RAMP.
- H. THE LEADING EDGE OF THE DETECTABLE WARNING SURFACE SHALL BE LOCATED 6" TO 8" FROM THE GUTTER FLOW-LINE. DETECTABLE WARNING SURFACES SHALL BE INSTALLED PARALLEL TO THE PATH OF TRAVEL, AND SHALL EXTEND THE FULL WIDTH OF THE PATH OF TRAVEL, AND A MINIMUM DEPTH OF 3' FROM THE LEADING EDGE TOWARDS THE BACK OF THE RAMP.
- I. SLOPES OVER THE MAXIMUM ALLOWED IN THIS AREA WILL REQUIRE WRITTEN APPROVAL BY THE CITY ENGINEER.

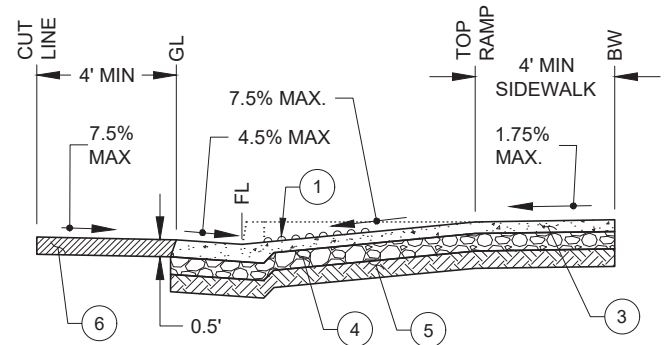

**SECTION 'A-A'**

①	DETECTABLE WARNING SURFACE (SEE STANDARD DETAIL #210 AND NOTE G & H ABOVE).
②	DEEP TOOL JOINT 1-1/2 INCH MIN., (SEE STD. DETAIL 202 FOR SPACING).
③	4,000 PSI MIN. CONCRETE, 4" THICK FOR SIDEWALKS / RAMPS & 6" THICK FOR GUTTER AREAS.
④	CLASS II (3/4" MAX) AB PROCESSED TO 95% RELATIVE COMPACTION. 4 INCH THICK UNDER SIDEWALK, 6 INCH UNDER CURB & GUTTER.
⑤	6 INCH SUBGRADE OR, IF REQUIRED, CLASS II (3/4" MAX.) ASB. EITHER MATERIAL SHALL BE PROCESSED TO 95% RELATIVE COMPACTION.

⑥	SAW CUT, REMOVE AND REPLACE A MIN DEPTH OF 6" OF AC OR MATCH EXIST. DEPTH WHICHEVER IS GREATER
⑦	INSTALL 12" LENGTHS OF #4 REBAR SPACED 18" O.C. IN THE EXISTING CONCRETE BY CORING OR DRILLING 1/8" LARGER HOLE THAN REBAR INTO THE EXISTING CONCRETE (4" MIN.). BRUSH/BLOWOUT HOLES, INSTALL THE REBAR, AND FILL THE ANNULAR VOIDS WITH EPOXY.

**THE CITY OF WEST SACRAMENTO - STANDARD DETAIL**



APPROVED: Aug. X, 2025

STANDARD  
DETAIL #  
**209 A**

TITLE:  
**PERPENDICULAR  
CURB RAMP  
RETROFIT**

