

**DETAIL "A"**

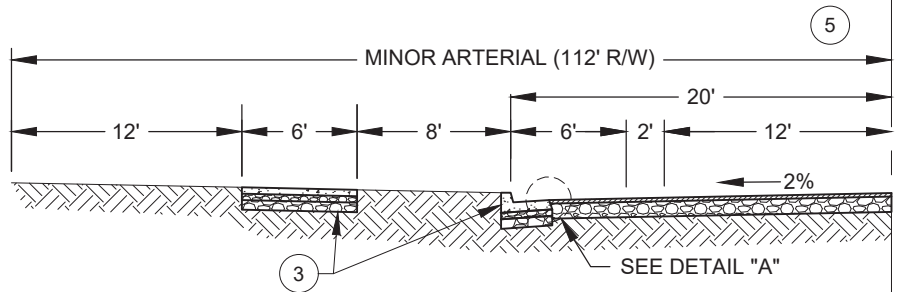

1	CURB, GUTTER AND SIDEWALK PER DETAIL #201
2	TYPE "A" MEDIAN CURB PER DETAIL #203 & #204
3	CURB, GUTTER AND SEPARATED SIDEWALK PER DETAIL #202
4	PARKING ALLOWED, SIDEWALK AND NO BICYCLE LANE BOTH SIDES
5	NO PARKING, STRIPED AND GREEN PAINTED BICYCLE LANE WITH 2' STRIPED BUFFER AND 16' WIDE MEDIAN

**NOTES**

A. INTERSECTIONS MAY REQUIRE ADDITIONAL R/W TO ACCOMMODATE LEFT/RIGHT TURN LANES.

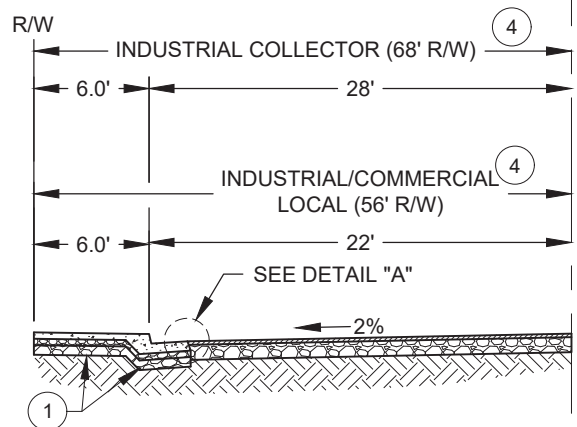

**THE CITY OF WEST SACRAMENTO - STANDARD DETAIL**



APPROVED: Aug. X, 2025

STANDARD  
DETAIL #

**222**

TITLE:

**SOUTHPORT STREET  
SECTIONS COMM. INDUST.  
AND ARTERIAL STREETS**

