

MINIMUM LOT SIZE = 1 ACRE

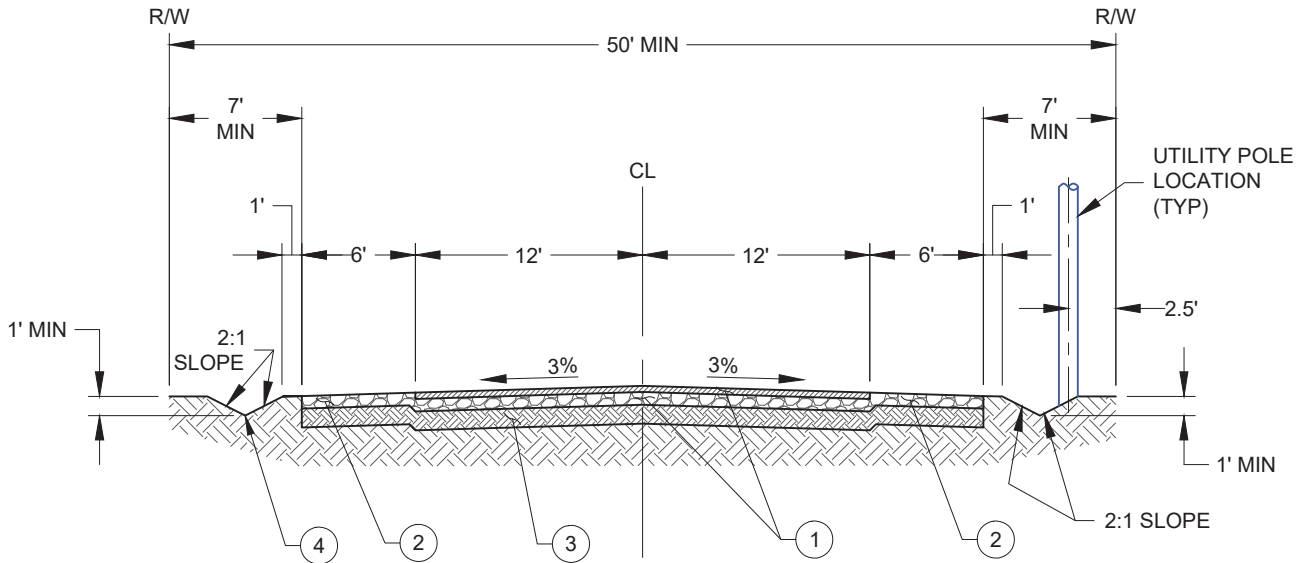

①	SECTION BASED ON STRUCTURAL DESIGN THROUGH A SOILS REPORT. SEE DIV. I SECTION 3.01 OF THESE STANDARD SPECIFICATIONS. MINIMUM TRAFFIC INDEX = 6.0. MINIMUM 2" AC OVER 4" AB PROCESSED TO 95% RELATIVE COMPACTION.
②	MINIMUM 4" AB SHOULDERS PROCESSED TO 95% RELATIVE COMPACTION. SEE NOTE ①
③	MINIMUM 6" SUBGRADE PROCESSED TO 95% RELATIVE COMPACTION. SEE NOTE ①
④	ROADSIDE DITCH GRADING SHALL BE DESIGNED TO FIT WITHIN DEDICATED R/W AS THE SLOPES DETAILED IN THIS DETAIL.

THE CITY OF WEST SACRAMENTO - STANDARD DETAIL



APPROVED: Aug. X, 2025

STANDARD
DETAIL #

228

TITLE:
**RURAL ROAD
SECTION**

