

FRONT VIEW

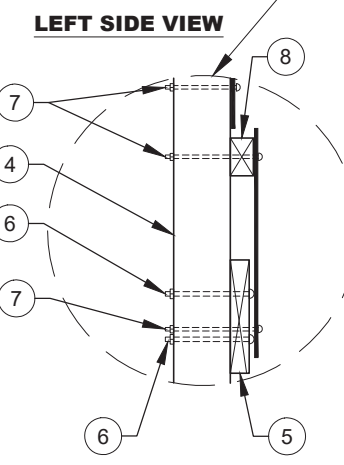

LEFT SIDE VIEW

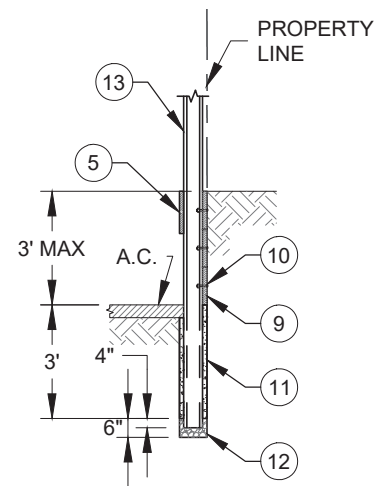

BARRICADE WITH RETAINING WALL RIGHT SIDE VIEW

1	W31 SIGN. 24" x 24".
2	TYPE "OM4-3" SIGN. 18" x 18" (RED REFLECTIVE BACKGROUND WITH BLACK BORDER, NO REFLECTORS).
3	POST AT CENTER OR NEAR THE CENTER OF THE RIGHT HALF OF THE ROAD.
4	6" x 6" x 6' MIN. TREATED DOUGLAS FIR POST (STATE OF CA SPECS 56-2.02B) (TYP POSTS).
5	2" x 12" DOUGLAS FIR OR HEM-FIR BOARD.
6	1/2" CARRIAGE GALVANIZED STEEL BOLTS WITH WASHERS & NUTS. (TYP FOR FASTENING 2" x 12" BOARD)
7	5/16" MACHINE GALVANIZED STEEL BOLT OR EQUAL WITH WASHERS AND NUTS. (TYP FOR FASTENING SIGNS).
8	WOOD BLOCK SPACER.
9	2" x 12" PRESSURE TREATED LUMBER DESIGNED FOR DIRECT CONTACT WITH NATIVE SOIL / EARTH, RETAINING WALL WHERE DESIRED SLOPE CANNOT BE OBTAINED.
10	3/8" GALVANIZED STEEL BOLTS, WASHERS AND NUTS: ONE EACH BOARD AT EACH POST.
11	1' DIAMETER, 4,000 PSI CONCRETE AGAINST ORIGINAL GROUND
12	1' DIAMETER DRAIN ROCK 6" MIN BELOW CONCRETE FOUNDATION
13	6 WF 25 STEEL POST PER CALTRANS SS SECTION 55 @ 4' C-C

NUMBER & SIZE OF SIGNS				
R/W WIDTH	W31		TYPE "OM4-3"	
	SIZE	NO.	SIZE	NO.
50' 56' & 60'	24"	2	18"	2
64' - 84'	24"	2	18"	2
OVER 100' WITH MEDIAN ISLAND	24"	4	18"	4
OVER 100' WITHOUT MEDIAN ISLAND	24"	5	18"	5

- NOTES:**
- A. ALL EXPOSED WOOD SURFACES (EXCEPT RETAINING WALL BOARDS) SHALL BE PAINTED WITH WHITE PAINT CONFORMING TO STATE STANDARD SPECIFICATION 91-3.

THE CITY OF WEST SACRAMENTO - STANDARD DETAIL



APPROVED: Aug. X, 2025

STANDARD
DETAIL #
241

TITLE:
**STREET
BARRICADE**

