

- NOTES:**
1. AC DESIGN HEIGHT = 3.75"
MIN. = 3.25"
MAX. = 3.75"
 2. PLACE W17-1 "SPEED" HUMP SIGN AND W13-1P "15 MPH" ADVISORY SIGN ON SAME POST, APPROXIMATELY 50' PRIOR TO SPEED BUMP, ACCORDING TO CONTEXT PLAN.

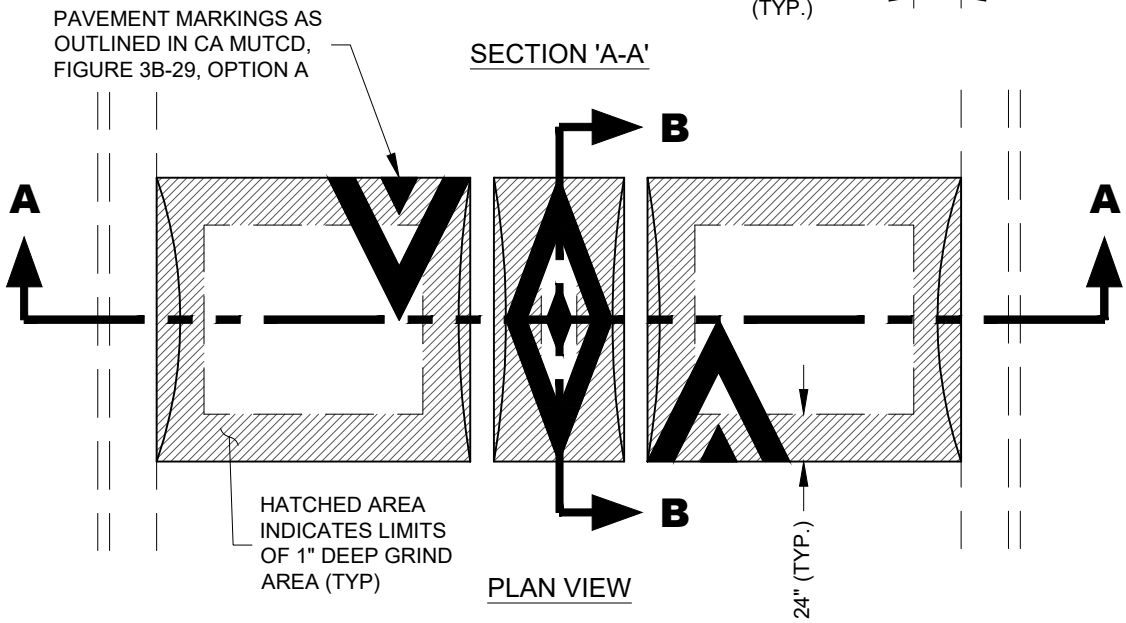

THE CITY OF WEST SACRAMENTO - STANDARD DETAIL

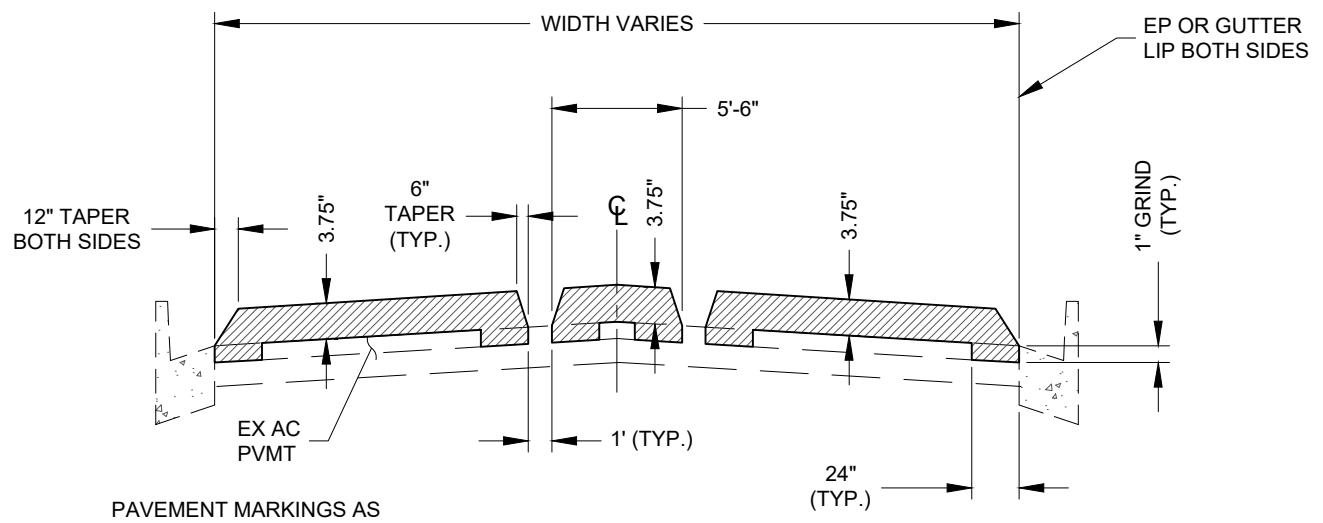

APPROVED: Aug. X, 2025

STANDARD
DETAIL #
256

TITLE:
**SPEED HUMP
TYPE A**

