

\* BOLLARDS SHALL BE PAINTED WITH 1 PRIME COAT AND 2 COATS OF HIGH GLOSS WHITE RUST INHIBITIVE PAINT.

**SECTION B-B**

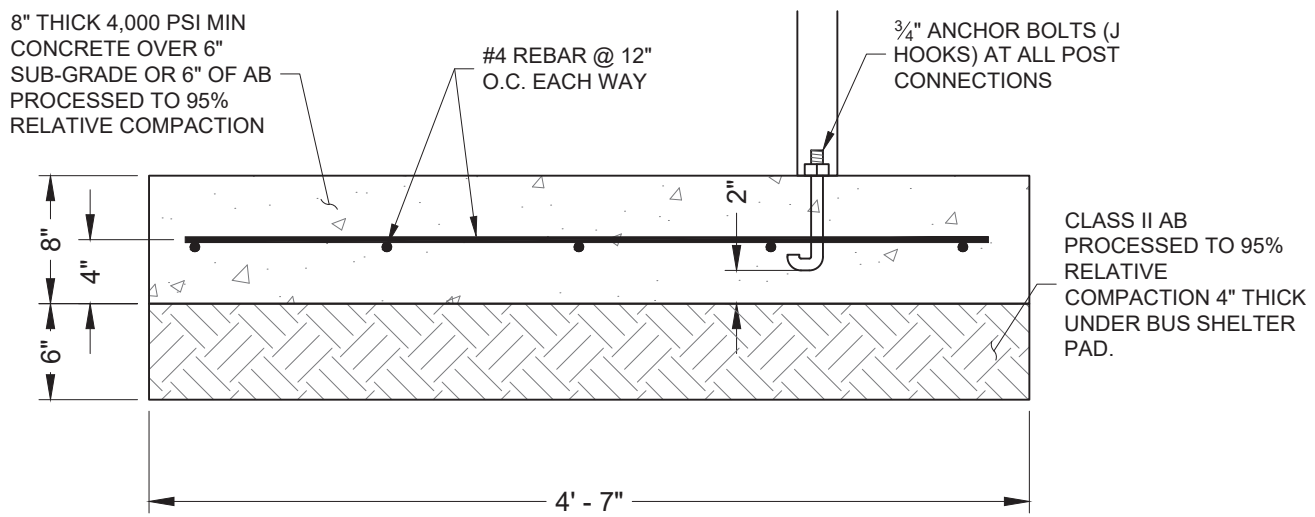

**BUS SHELTER FOUNDATION DETAIL**

**THE CITY OF WEST SACRAMENTO - STANDARD DETAIL**



APPROVED: Aug. X, 2025

STANDARD  
DETAIL #  
**262 C**

TITLE:  
**BUS SHELTER  
RIGHT SIDE VIEW  
(SECTION B-B) &  
FOUNDATION DETAIL**

