

①	SCHEDULE 80 PVC FROM METER ANGLE STOP TO MINIMUM SIX (6) INCHES OUTSIDE THE METER BOX OR AS APPROVED BY THE CITY ENGINEER. USE SCHEDULE 80 NIPPLE WITH THREADED CONNECTION TO METER ANGLE STOP.
②	"SENSUS" WATER METER MODEL SR11 SERIES WITH ENCODED DIGITAL REGISTER FOR 1 INCH. OR CITY APPROVED EQUAL.
③	"SENSUS" MODEL 520M FLEXNET SMARTPOINT M2 RADIO TRANSCEIVER (MXU) OR APPROVED EQUAL MOUNTED ON A MOLDED SLIDE MOUNT BRACKET LOCATED ON THE BOTTOM SIDE OF THE LID.
④	BALL CORPORATION STOP.
⑤	SERVICE SADDLE.
⑥	IRON PIPE SIZE POLYETHYLENE SERVICE TUBING.
⑦	CONNECT SERVICE TRACER WIRE TO WATER MAIN TRACER WIRE. SPLICES SHALL BE "KURNEY" (SPLIT BOLT) OR "KUP-L-TAP". INSTALLATION TAPE SHALL BE 3M ELECTRICAL TAPE WITH TWO COATS OF "SCOTCHKOTE FD" ELECTRICAL COATING OR APPROVED EQUAL. TRACER WIRE SHALL BE TAPED TO WATER SERVICE WITH 10 MIL TAPE AT MIN 10 FOOT INTERVAL.

⑧	BALL ANGLE METER STOP WITH LOCK EARS.
⑨	CONNECT SERVICE TRACER WIRE TO WATER MAIN TRACER WIRE WITH #10 AWG SOLID COPPER WIRE WITH U.S.E. RATED INSULATION, COLOR BLUE.
⑩	CURB, GUTTER, AND SIDEWALK WITH A 2" x 2" LETTER "W" STAMPED, CHISELED INTO TOP OF CURB DIRECTLY ABOVE LOCATION WHERE WATER SERVICE CROSSES FLOW LINE OF CONCRETE GUTTER.
⑪	RESERVED
⑫	WATERMAIN.
⑬	1/2 INCH CRUSHED ROCK, 12 INCHES DEEP.
⑭	METER BOXES SHALL BE CHRISTY B16 AND B16C4-4A COVER OR APPROVED EQUAL. BOXES AND LIDS LOCATED IN SIDEWALKS AND DRIVEWAYS SHALL BE GRAY IN COLOR AND BOXES LOCATED IN LANDSCAPE AREAS SHALL BE GREEN IN COLOR. ALL BOX COVERS SHALL BE MARKED "WATER", AS SUPPLIED BY DFW PLASTICS, INC. OR CITY APPROVED EQUAL. BOXES AND LIDS IN GRASS OR LANDSCAPED AREA SHALL BE GREEN IN COLOR. ALL LIDS SHALL READ "WATER". BOXES AND LIDS LOCATED IN CONCRETE DRIVEWAYS AND SIDEWALKS SHALL BE GRAY IN COLOR.

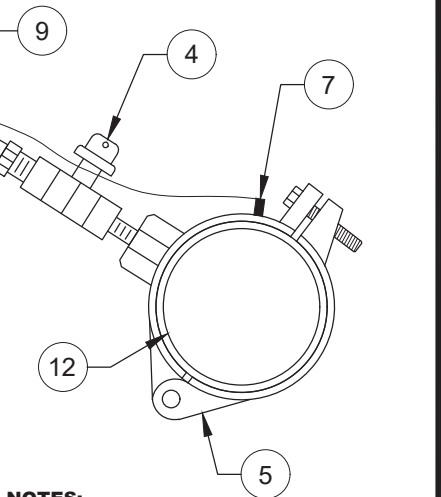

- NOTES:**
- A. STANDARD DETAIL IS FOR RESIDENTIAL DOMESTIC AND FIRE FLOWS.
 - B. METER SIZE SHALL MATCH LINE SIZE OR AS APPROVED BY CITY ENGINEER.
 - C. SEE MANUFACTURER'S INSTRUCTIONS FOR CONNECTION FROM REGISTER TO MXU. VERIFICATION THAT THE MXU HAS BEEN PROPERLY CONNECTED AND PROGRAMMED SHALL BE MADE BY THE CITY ENGINEER.
 - D. COIL EXCESS TRACER WIRE IN BOTTOM OF METER BOX.



STANDARD
DETAIL #
501

TITLE:
**SINGLE FAMILY
RESIDENTIAL SERVICE
AND METER
ASSEMBLY 1"**

